

1 Place floor rails as shown. Nail floor panels to rails using 6 x 40 mm lost head nails per board. Note: The two panels with rebate edge joint go to the rear and the longer panel to the front, chamfer forward, projecting equally on both sides.

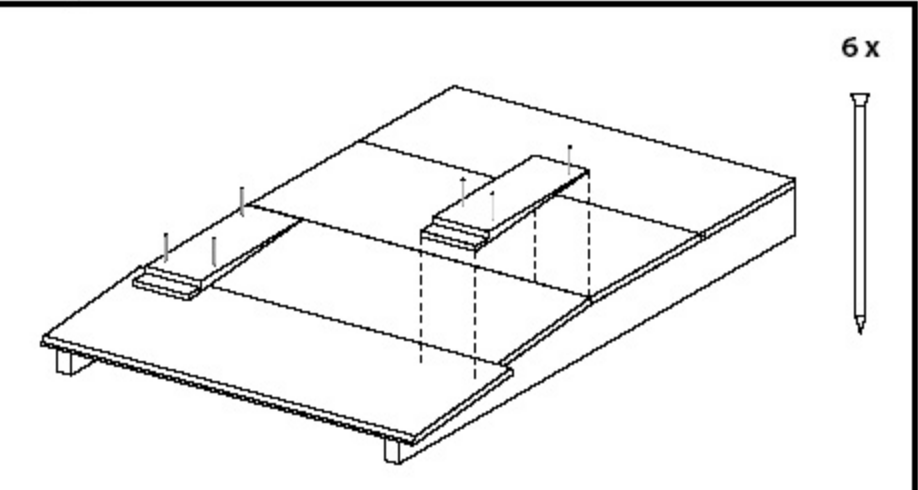

2 Position support wedges as shown, Note: Top of wedge should be level with flat area of floor. Nail support wedges to floor using 6 x 25 mm pins.

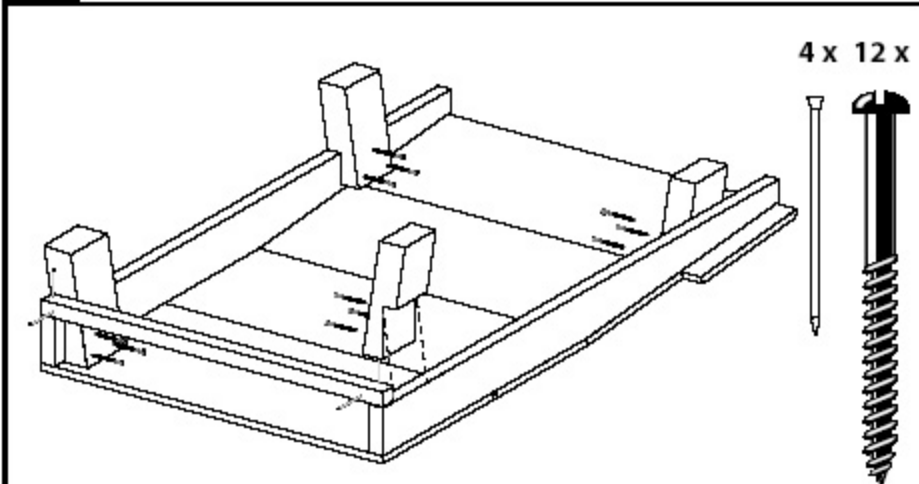

3 Turn floor over and position rear bracing block. Nail to floor rails using 2 x 25 mm pins. Position rear legs (Note: Rear legs are longer) and fix using 6 x 40mm black Japanned screws. Nail block to rear legs using 2 x 25 mm pins. Slide front legs forward until they touch underside of floor panels and fix using 6 x 40 mm black Japanned screws.

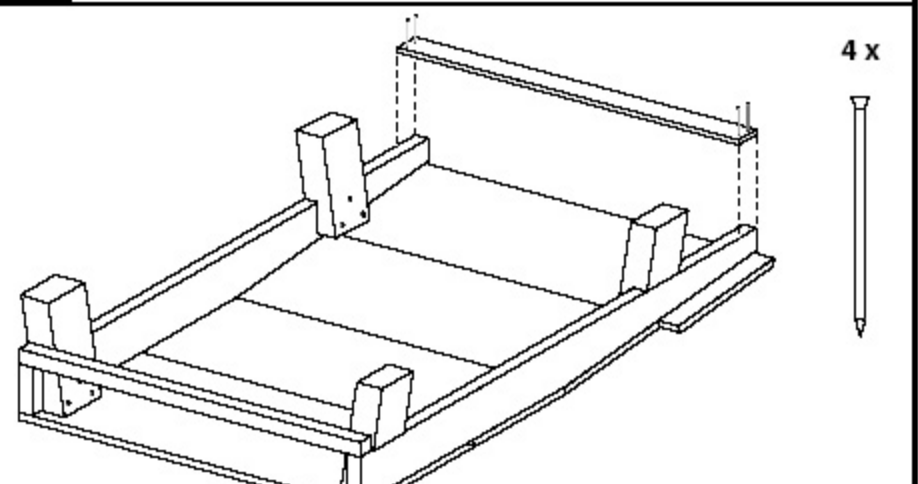

4 Position front bracing strip as shown and nail into position using 4 x 25 mm pins.